



Optimus Mitsubishi AC Gateway User Manual

Version 1.0.0

Optimus

April 1, 2026

Database Version 1.0.0

Contents

1	DOCUMENT CONTENT	3
2	INTRODUCTION	3
3	BEFORE YOU START	3
4	FUNCTIONS	4
4.1	GENERAL	5
4.1.1	Startup Delay	5
4.1.2	Alive Notifications	5
4.1.3	Remote Control Lock	5
4.1.4	Object Control Lock	6
4.1.5	PARAMETER LIST	7
4.1.6	GROUP OBJECT LIST	8
4.2	AC GENERAL	8
4.2.1	PARAMETER LIST	9
4.2.2	GROUP OBJECT LIST	10
4.3	AC MODE	10
4.3.1	Mode +/- Object	10
4.3.2	Heat/Cool Mode Object	11
4.3.3	Mode Individual Object	11
4.3.4	PARAMETER LIST	11
4.3.5	OBJECT LIST	12
4.4	Fan	14
4.4.1	Number of Fan Level	15
4.4.2	Fan Auto Level	15
4.4.3	Fan Level Object	16
4.4.4	Fan Level +/- Object	17
4.4.5	Fan Level Individual Object	17
4.4.6	PARAMETER LIST	17
4.4.7	OBJECT LIST	19
4.5	Vane	20
4.5.1	Number of Vane Positions	21
4.5.2	Vane Auto Position	21
4.5.3	Swing Mode	22
4.5.4	Vane Position Object	22
4.5.5	Vane Position +/- Object	23
4.5.6	Vane Position Individual Object	23
4.5.7	PARAMETER LIST	23
4.5.8	OBJECT LIST	25
4.6	Wide Vane	27
4.7	AC Temperature	27
4.7.1	Setpoint Temperature Feedback	28

4.7.2	Setpoint Temperature +/- Object	29
4.7.3	Setpoint Temperature Limiting	29
4.7.4	Ambient Temperature	30
4.7.5	Ambient Temperature Feedback	30
4.7.6	Virtual Setpoint Calculation	31
4.7.7	PARAMETER LIST	33
4.7.8	OBJECT LIST	35
4.8	Energy Saving function	36
4.8.1	Window Contact	37
4.8.2	PARAMETER LIST	41
4.8.3	OBJECT LIST	46
4.9	Scene function	47
4.9.1	Scene 1	48
4.10	Save/Exec Function	50
4.10.1	PARAMETER LIST	51
4.10.2	OBJECT LIST	53
4.11	Additional Function	54
4.11.1	Function 1	55
4.11.2	PARAMETER LIST	65
4.11.3	OBJECT LIST	68
5	Main Technical Features	70
6	Wiring Diagram	70
6.1	CN105 Port	70
6.2	TB15 Port	71

1 DOCUMENT CONTENT

This document contains the features and functions of the Optimus MitsubishiAC Gateway product. Optimus MitsubishiAC Gateway is compatible with KNX switches and Mitsubishi indoor unit models.

2 INTRODUCTION

Optimus MitsubishiAC Gateway is an interface that provides bidirectional communication between the KNX home and building automation system and air conditioners. Optimus MitsubishiAC Gateway is used to monitor and control the functions of KNX and air conditioners. Thus, the air conditioning system can be controlled from the KNX home and building automation system.

It is compatible with all models of the PAC, RAC, City Multi VRF and MrSlim air conditioner series of Mitsubishi Electric.

There are two options according to the way of connecting to the Optimus mitt air conditioner indoor unit. One model is connected to the cn105 port of the A/C indoor unit, and the other model is connected to the tb15 port.

If the device is connected to the Tb15 port, the air conditioner setting should be made so that the thermistor data (ambient temperature) of the air conditioner indoor unit is received from the remote control.

Visit <https://optimusst.com/product-detail/ac-gateway> for the compatibility list.

If CN105 is to be used as a connection port, the air conditioner setting must be made so that the thermistor data (ambient temperature) is over the air conditioner indoor unit. For the relevant settings, refer to the user manual of the air conditioner.

Visit <https://optimusst.com/product-detail/ac-gateway> for the compatibility list.

3 BEFORE YOU START

First of all, it is important to understand how Optimus MitsubishiAC Gateway works.

Yellow LED Behaviour

If you have configured the device correctly and communication with the air conditioner has begun, you should see the yellow LED blinking. If the yellow LED is not blinking:

- Make sure you selected the correct device as explained in the "AC General" section.
- Make sure the air conditioner communication cable is connected properly. If the communication cable is faulty, Optimus MitsubishiAC Gateway will not be able to communicate with the AC.

When the yellow LED starts blinking, all Feedback objects assigned to a group address will send the current status of the air conditioner to the KNX Bus.

If you see the yellow LED staying on continuously, this means that Optimus MitsubishiAC Gateway was communicating with the air conditioner for a while, but is currently unable to communicate.

If the yellow LED never lights up (no blinking and no solid light), this means that Optimus MitsubishiAC Gateway has not established any communication with the air conditioner. Check the configuration and the communication cable.

Important warning

If the yellow LED is blinking, you write a value to one of the set objects, and there is no feedback, this means that the written value is either not accepted by the air conditioner or is outside of the valid limits.

Example Scenario: None of the air conditioners compatible with Optimus MitsubishiAC Gateway accept a set temperature higher than 32°C. If you write 40°C to the "Setpoint Temperature" group address, this value will be completely ignored, and no response will be sent from the "Setpoint Temperature Feedback" object.

Another Example Scenario: Depending on your configuration, Optimus MitsubishiAC Gateway supports fan levels 3, 4, and 5. If you write a fan value higher than your selected configuration – for example, 7 – to the "Fan Level" object there will be no response from the "Fan Level Feedback" object.

This behavior is the same for all Feedback objects.

4 FUNCTIONS

The most outstanding features of Optimus MitsubishiAC Gateway:

- Bidirectional control of HVAC units through their relevant ports.
- Control of the main functions of the A/C unit: On/Off, temperature, mode of operation, fan speed, vane / flap control, etc.
- Error management to handle specific error codes from the A/C unit itself as well as any communication issues that may arise.
- Up to ten scenes.
- Energy Saving functions.
- Three digital inputs.
- External Thermistor Input.
- 2 functions defined as additional functions and 2 customizable logic functions for each function, 4 arithmetic operations, 6 different comparison processes, 3 different data type

conversion.

- Alive notifications.

4.1 GENERAL

There are some general parameters that apply to each section. These:

4.1.1 Startup Delay

Startup delay	<input type="text" value="10"/>	Seconds
---------------	---------------------------------	---------

This function is used to determine how long after the product is powered on (connected to the KNX bus) it will start communication. A minimum delay of 5 seconds is set as the default value. With this function, different delays can be assigned to gateways on the KNX bus, helping to manage bus load.

4.1.2 Alive Notifications

Alive notification	<input type="radio"/> Disable <input checked="" type="radio"/> Enable	
Period	<input type="text" value="20"/>	Seconds

This function plays a crucial role in determining whether the product is operational. By enabling this feature in the parameters, it is possible to check if the device is working. The "Enable" value is sent at a periodic interval defined in the period section via the "Alive Notification" object. Receiving this data periodically indicates that the device is up and running.

4.1.3 Remote Control Lock

Remote control lock	<input checked="" type="radio"/> Disable <input type="radio"/> Enable
---------------------	---

The remote control can be locked via the "Remote Control Lock" object. When the lock is in the "Enable" position, all commands from the air conditioner's remote control are blocked and ignored. However, this does not affect the control of the unit via KNX.

When the "Remote Control Lock" is activated, commands sent from the central controller connected to the outdoor unit are not transmitted to the indoor unit where Optimus MitsubishiAC Gateway is connected. Even if a change is momentarily observed on the central controller, the air conditioner's state will revert to its previous condition within a few seconds. The same applies to other controllers directly connected to the indoor unit.

Important note for TB15: If Optimus MitsubishiAC Gateway is connected to the Tb15 port, and a wired remote controller is also connected to the indoor unit, the remote controller must be set to operate in slave mode.

4.1.4 Object Control Lock

Object control lock Disable Enable

When the device lock is activated via the "**Object Control Lock**" object, the device becomes blocked and can no longer be controlled by any group object. Until the lock is deactivated, the device will not respond to any commands over the KNX bus. Even if the device receives a value during the locked state, it will retain its last status before the lock was applied once the lock is removed.

4.1.5 PARAMETER LIST

This section provides a summary list of the parameters under the "General" section.

Parameters	Sub Par. 1	Sub Par. 2	Values	Conditions	Details
Startup delay			5...65535 seconds		Allows defining how long after connecting to the KNX bus the device will become active.
Alive notification	Period		Disable/Enable 5...65535 seconds	If "Alive Notification" Enabled	Allows the device to periodically send the value "true" while it is operating. This sub-parameter defines the frequency, in seconds, at which the "Alive Notification" (indicating that the device is running) will be sent.
Remote control lock			Disable/Enable		Determines whether the use of the air conditioner's remote control can be locked through the lock object.
Object control lock			Disable/Enable		Determines whether the device can be locked through the lock object.
Energy saving function			Disable/Enable		Determines whether the "Energy Saving Function" parameter will be activated.
Scene function			Disable/Enable		Determines whether the "Scene Function" parameter will be activated.
Additional function			Disable/Enable		Determines whether the "Additional Function" parameter will be activated.

4.1.6 GROUP OBJECT LIST

OBJECT	FUNCTION	TYPE	FLAG
Alive Status	Alive Notification	1 bit	CRT
This object is only visible when the "Alive Notification" parameter is enabled. While Optimus MitsubishiAC Gateway is running, the value "true" is sent through the connected group address, indicating that the device is operational.			
Remote Control Lock	1:Enabled / 0:Disabled	1 bit	CRWU
This object is only visible when the "Remote Control Lock" parameter is enabled. With this object, control of the air conditioner via the remote control is blocked.			
Object Control Lock	1:Enabled / 0:Disabled	1 bit	CRWU
This object is only visible when the "Error Status" parameter is enabled. It reports the error status.			

4.2 AC GENERAL

AC Model Mitsubishi Electric ▼

Slave Function Disable Enable

Fan control

Vane control

Wide vane control

Error status On change or on request ▼

Behaviour after bus voltage failure No reaction ▼

To see the parameters needed for basic air conditioner functions like fan and Wane(louver) control, they must be activated in the AC General section.

The air conditioner error feedback is activated through the **"Error Status"** parameter.

The **"Operation Hours counter"** parameter is used to control operation times and scheduled tasks.

The **"Behaviour after bus voltage"** parameter is used to determine the device's behavior in case of a power loss on the KNX bus.

If the Optimus MitsubishiAC Gateway is to operate in parallel with a wired controller and is required to act as a slave, the **"Slave Function"** must be enabled.

4.2.1 PARAMETER LIST

Parameter	Sub Par. 1	Sub Par. 2	Values	Conditions	Details
Fan control			Disable/Enable		Determines whether the parameter required for controlling the fan speed will be activated or not.
Vane control			Disable/Enable		Determines whether the parameter required for controlling the vane position will be activated or not.
Error status	Period		Disable On request On change or on request Cyclical or on request 5...65535 seconds	The Error Status parameter becomes active if "Cyclical or on request" is selected.	Determines whether the feedback for the air conditioner's errors will be provided or not. This sub-parameter is used to determine the frequency of error feedback in seconds.
Behaviour after bus voltage failure	Scene		No reaction AC off Scene		This parameter determines the behavior to be applied after a KNX bus voltage failure.
	Scene		1..10	If the "Behaviour after bus voltage failure" parameter is set to Scene.	This sub-parameter allows selecting a predefined scenario after a KNX bus voltage failure.

4.2.2 GROUP OBJECT LIST

OBJECT	FUNCTION	TYPE	FLAG
On/Off	1:On / 0:Off	1 bit	CWU
This object is always visible. The air conditioning unit is controlled via the connected group address.			
On/Off Feedback	1:On / 0:Off	1 bit	CRT
This object is always visible. The status of the air conditioning unit is monitored through the connected group address.			
Error Status	ASCII	14 byte	CRT
This object is only visible when the "Error Status" parameter is enabled.If there is an error in the air conditioner, it displays the corresponding error code.			
Error Alarm	1:On / 0:Off	1 byte	CRT
This object is always visible. It reports the error status. If the connection with the air conditioner cannot be established, this group object takes the value 1. If everything is normal and operating correctly, it takes the value 0.			

4.3 AC MODE

Cool mode	<input type="radio"/> Disable	<input checked="" type="radio"/> Enable
Heat mode	<input type="radio"/> Disable	<input checked="" type="radio"/> Enable
Dry mode	<input type="radio"/> Disable	<input checked="" type="radio"/> Enable
Fan mode	<input type="radio"/> Disable	<input checked="" type="radio"/> Enable
Auto mode	<input type="radio"/> Disable	<input checked="" type="radio"/> Enable

The modes that the indoor unit can operate in can be defined. Each desired mode can be enabled or disabled.

4.3.1 Mode +/- Object

Mode +/- object	<input type="radio"/> Disable	<input checked="" type="radio"/> Enable
-----------------	-------------------------------	---

If this parameter is enabled, the Mode +/- group object (1: Increase / 0: Decrease) will be available. If the value 1 is written to this object, the mode transition sequence will be as follows:

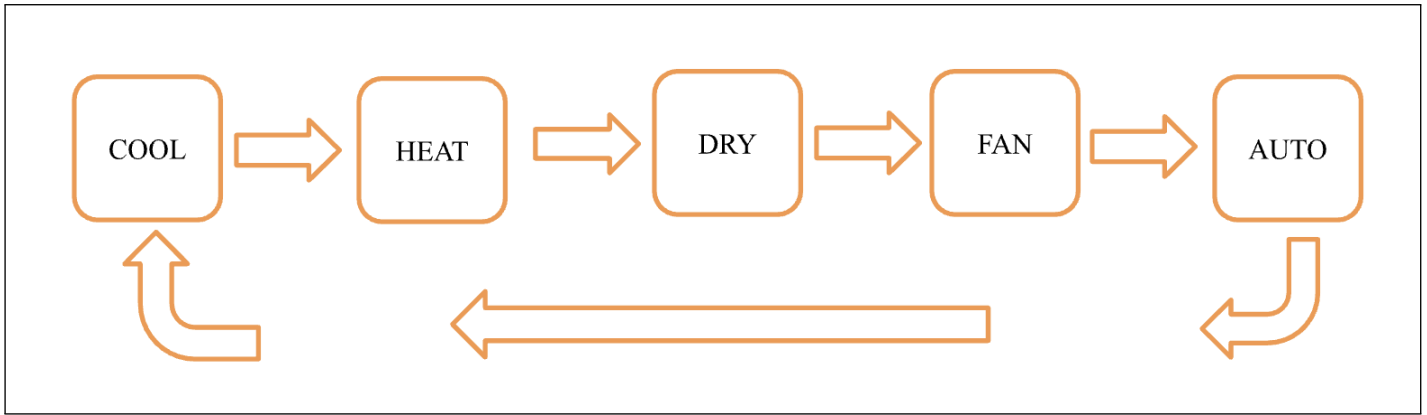

4.3.2 Heat/Cool Mode Object

Heat/Cool Mode object Disable Enable

This parameter allows the air conditioner's mode to be set to either Heat or Cool using a 1-bit group object.

By writing 1 or 0 to the "Heat/Cool Mode Set" group object the air conditioner will be switched to Heat mode when a value of 1 and to Cool mode when a value of 0 is sent.

4.3.3 Mode Individual Object

Mode individual objects Disable Enable

The "Mode Individual Object" parameter, when enabled, allows each mode to be selected individually.

4.3.4 PARAMETER LIST

Parameter	Sub Par. 1	Sub Par. 2	Values	Conditions	Details
Cool Mode			Disable/Enable		This parameter determines whether the Cool mode can be used.

Parameter	Sub Par. 1	Sub Par. 2	Values	Conditions	Details
Heat Mode			Disable/Enable		This parameter determines whether the Heat mode can be used.
Dry(Dehumifcation) Mode			Disable/Enable		This parameter determines whether the Dry(Dehumifcation) mode can be used.
Fan(Fan Only) Mode			Disable/Enable		This parameter determines whether the Fan(Fan Only) mode can be used.
Auto Mode			Disable/Enable		This parameter determines whether the Auto mode can be used.
Mode +/- object			Disable/Enable		This parameter is used for switching between air conditioning modes.
Heat/Cool Mode Object			Disable/Enable		This parameter allows the air conditioner's mode to be set to either Heat or Cool using a 1-bit group object.
Mode individual objects			Disable/Enable		When this parameter is enabled, a 1-bit object is created for each mode. This allows the air conditioner's mode to be changed by simply sending a value of 1 to the corresponding object.

4.3.5 OBJECT LIST

OBJECT	FUNCTION	TYPE	FLAG
Mode	Cool-Heat-Dry(Dehumifcation)-Fan(Fan Only)-Auto	1 byte	CWU

OBJECT	FUNCTION	TYPE	FLAG
<p>This object is always visible.</p> <p>Used to set the mode of the air conditioner. The mode can be changed using the following values:</p> <p>0: Auto 1: Heat 3: Cool 9: Fan(Fan Only) 14: Dry(Dehumidification)</p>			
Mode Feedback	Cool-Heat-Dry(Dehumidification)- Fan(Fan Only)-Auto	1 byte	CRT
<p>Used to display the operating mode of the air conditioner. It shows one of the following values based on the air conditioner's active mode:</p> <p>0: Auto 1: Heat 3: Cool 9: Fan(Fan Only) 14: Dry(Dehumidification)</p>			
Mode +/-	1:Increase / 0:Decrease	1 bit	CWU
<p>This object is only visible when the "Mode +/- Set" parameter is enabled. This object allows switching between operating modes in a +/- manner.</p>			
Heat/Cool Mode Set	1:Heat/0:Cool	1 bit	CWU
<p>This object is only visible when the "Heat/Cool Mode Object" parameter is enabled. With the help of this group object, the heating and cooling modes of the air conditioner can be changed. A value of 1 should be used for heat mode, and 0 for cool mode.</p>			
Cool Mode Set	1:Enable / 0:Disable	1 bit	CWU
<p>This object is only visible when the "Mode Individual Object" parameter is selected. It allows switching to Cool Mode with an incoming 1-bit value.</p>			
Heat Mode Set	1:Enable / 0:Disable	1 bit	CWU
<p>This object is only visible when the "Mode Individual Object" parameter is selected. It allows switching to Heat Mode with an incoming 1-bit value.</p>			
Dry(Dehumidification) Mode Set	1:Enable / 0:Disable	1 bit	CWU
<p>This object is only visible when the "Mode Individual Object" parameter is selected. It allows switching to Dry(Dehumidification) Mode with an incoming 1-bit value.</p>			
Fan(Fan Only) Mode Set	1:Enable / 0:Disable	1 bit	CWU
<p>This object is only visible when the "Mode Individual Object" parameter is selected. It allows switching to Fan(Fan Only) Mode with an incoming 1-bit value.</p>			
Auto Mode Set	1:Enable / 0:Disable	1 bit	CWU
<p>This object is only visible when the "Mode Individual Object" parameter is selected. It allows switching to Auto Mode with an incoming 1-bit value.</p>			
Heat Mode Feedback	1:Enable / 0:Disable	1 bit	CWU

OBJECT	FUNCTION	TYPE	FLAG
This object is only visible when the "Mode Individual Object" parameter is selected. It allows monitoring the Heat Mode of the air conditioner.			
Cool Mode Feedback	1:Enable / 0:Disable	1 bit	CWU
This object is only visible when the "Mode Individual Object" parameter is selected. It allows monitoring the Cool Mode of the air conditioner.			
Dry(Dehumifcation) Mode Feedback	1:Enable / 0:Disable	1 bit	CWU
This object is only visible when the "Mode Individual Object" parameter is selected. It allows monitoring the Dry(Dehumifcation) Mode of the air conditioner.			
Fan(Fan Only) Mode Feedback	1:Enable / 0:Disable	1 bit	CWU
This object is only visible when the "Mode Individual Object" parameter is selected. It allows monitoring the Fan(Fan Only) Mode of the air conditioner.			
Auto Mode Feedback	1:Enable / 0:Disable	1 bit	CWU
This object is only visible when the "Mode Individual Object" parameter is selected. It allows monitoring the Auto Mode of the air conditioner.			

4.4 Fan

The parameters detailed below are used for controlling the air conditioner's fan levels. When selecting the fan level, the air conditioner's user manual should be referenced.

Important warning

If scaling is used to change fan values, please consider the following information:

Writing %0 to the "Fan Level" object sets the fan to Auto mode. For this reason, scaling values can be written in the range of 1–100. %0 is reserved for Auto Fan.

We recommend entering the highest value of your selected fan levels as 100%.

Example scenario:

Let's assume the following values:

Fan 1: 10%

Fan 2: 50%

Fan 3: 70%

Fan 4: 100%

In this case:

If you send 0% to the Fan Level object, the fan will switch to Auto.

If you send 5%, the fan will switch to Fan Level 1.

If you send 70%, the fan will switch to Fan Level 3.

If you send 75%, the fan will switch to Fan Level 4.

As shown in the example, you can switch to any target fan level by sending a value between the target level and the level below it.

Important warning

If you are using Scaling for Fan Level, the values you enter must not be lower than the previous level.

Correct example:

Fan 1 level limit: 5%
Fan 2 level limit: 30%
Fan 3 level limit: 50%
Fan 4 level limit: 70%
Fan 5 level limit: 100%

Incorrect example:

Fan 1 level limit: 5%
Fan 2 level limit: 30%
Fan 3 level limit: 50%
Fan 4 level limit: 45% // This value should be higher than the Fan 3 level limit
Fan 5 level limit: 100%

In summary: the values must follow this order:

Fan 1 < Fan 2 < Fan 3 < Fan 4 < Fan 5

4.4.1 Number of Fan Level

Number of fan level	<input type="text" value="3"/>
---------------------	--------------------------------

After activating the fan mode, the number of fan levels in the indoor unit should be defined through the "Number of fan level" parameter.

4.4.2 Fan Auto Level

Fan auto level	<input type="radio"/> Disable	<input checked="" type="radio"/> Enable
----------------	-------------------------------	---

The "Fan Auto Level" parameter defines whether the AUTO fan mode is available.

4.4.3 Fan Level Object

Fan level object	<input type="radio"/> Disable <input checked="" type="radio"/> Enable
Type	<input checked="" type="radio"/> Enumerated <input type="radio"/> Scaling

The fan level can be determined through various methods. When the Fan Level Object parameter is enabled, the active Fan Level Object allows the fan level to be set by entering data. To define the data type, two options in the Type parameter can be selected. If the "Enumerated" option is selected, the following values should be entered in the Fan Level object:

- "0" for Auto Fan Level
- "1" for Fan-1 Level
- "2" for Fan-2 Level
- "3" for Fan-3 Level
- "4" for Fan-4 Level

If the "Scaling" option is selected, a value can be assigned for each fan level.

Fan level object	<input type="radio"/> Disable <input checked="" type="radio"/> Enable
Type	<input type="radio"/> Enumerated <input checked="" type="radio"/> Scaling
i 0% is reserved for Auto. The limit values can be any number between 1% and 100%	
Fan level 1 limit	<input type="text" value="25"/> %
Fan level 2 limit	<input type="text" value="50"/> %
Fan level 3 limit	<input type="text" value="75"/> %
Fan level 4 limit	<input type="text" value="90"/> %

In the Scaling parameter, the specified values are entered in the Fan Level Object to set the fan level.

4.4.4 Fan Level +/- Object

Fan level +/- object Disable Enable

The Fan +/- Object parameter is used to switch between fan speeds. If this parameter is enabled, the "Fan Level +/- Set" group object (1: Increase / 0: Decrease) will be available.

If the value 1 is written to the related group address, the fan will switch to the next higher level. If the value 0 is written to the related group address, the fan will switch to the next lower level.

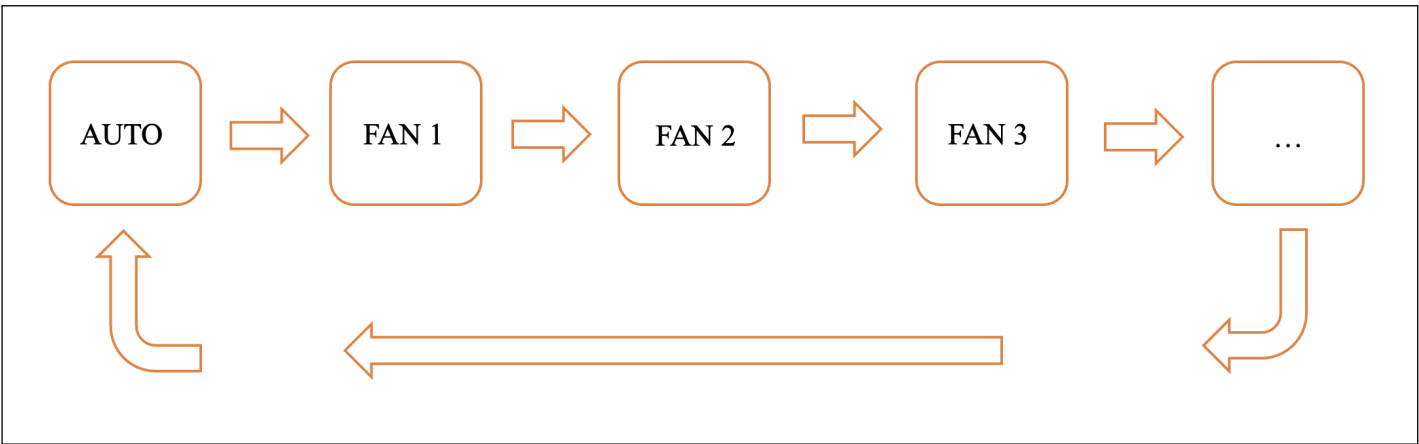

4.4.5 Fan Level Individual Object

Fan level individual objects Disable Enable

By activating the "Fan level Individual" Object, a separate object for each fan speed becomes visible, and each fan speed can be adjusted individually.

4.4.6 PARAMETER LIST

Parameter	Sub Par. 1	Sub Par. 2	Values	Conditions	Details
Number of fan level			2 3 4 5		This parameter can be set to 2, 3, 4, or 5 based on the number of fan levels of the air conditioner.

Parameter	Sub Par. 1	Sub Par. 2	Values	Conditions	Details
Fan auto level			Disable / Enable		This parameter determines whether the auto fan mode is enabled or not.
Fan level object	Type		Disable / Enable		This parameter determines whether the fan levels can be selected by entering data.
			Enumerated Scaling	If "Fan Level Object" is enabled	This sub-parameter determines the type of value that will be used to set the fan level.
		Fan level 1 limit	1...100%	If "Type" sub-parameter is "Scaling"	This sub-parameter selects the value to be assigned for Fan-1 level.
		Fan level 2 limit	1...100%	If "Type" sub-parameter is "Scaling"	This sub-parameter selects the value to be assigned for Fan-2 level.
		Fan level 3 limit	1...100%	If "Type" sub-parameter is "Scaling"	This sub-parameter selects the value to be assigned for Fan-3 level.
	Fan level 4 limit	1...100%	If "Type" sub-parameter is "Scaling"	This sub-parameter selects the value to be assigned for Fan-4 level.	
Fan level +/- object			Disable / Enable		This parameter allows the transition between fan speed levels using the +/- method.

Parameter	Sub Par. 1	Sub Par. 2	Values	Conditions	Details
Fan level individual objects			Disable/Enable		This parameter allows the selection of an object for each mode to individually choose the modes..

4.4.7 OBJECT LIST

OBJECT	FUNCTION	TYPE	FLAG
Fan Auto Level	1:Enable / 0:Disable	1 bit	CWU
This object is only visible when the "Fan Auto Level" parameter is enabled. This parameter activates the AUTO fan mode.			
Fan Auto Level Feedback	1:Enable / 0:Disable	1 bit	CRT
This object is only visible when the "Mode Individual Object" parameter is selected. This object is used to monitor the Fan Mode of the air conditioner.			
Fan Level +/- Set	1:Increase / 0:Decrease	1 bit	CWU
This object is only visible when the "Fan Level+/- object" parameter is selected. This object is used to adjust the fan speed of the air conditioner in a +/- manner.			
Fan Level Feedback	0...6	1 bit	CRT
This object is only visible when the "Fan Level+/- object" parameter is selected. This object is used to monitor the current fan speed.			
Fan Level-1 Set	1:Enable / 0:Disable	1 bit	CWU
This object is only visible when the "Fan level individual objects" parameter is selected. This object is used to set the fan speed to level 1.			
Fan Level-2 Set	1:Enable / 0:Disable	1 bit	CWU
This object is only visible when the "Fan level individual objects" parameter is selected. This object is used to set the fan speed to level 2.			
Fan Level-3 Set	1:Enable / 0:Disable	1 bit	CWU
This object is only visible when the "Fan level individual objects" parameter is selected. This object is used to set the fan speed to level 3.			
Fan Level-4 Set	1:Enable / 0:Disable	1 bit	CWU
This object is only visible when the "Fan level individual objects" parameter is selected. This object is used to set the fan speed to level 4.			
Fan Level-5 Set	1:Enable / 0:Disable	1 bit	CWU
This object is only visible when the "Fan level individual objects" parameter is selected. This object is used to set the fan speed to level 5.			
Fan Level-2 Feedback	1:Enable / 0:Disable	1 bit	CRT
This object is only visible when the "Fan level individual objects" parameter is selected. With this object, the fan level 2 is monitored.			
Fan Level-3 Feedback	1:Enable / 0:Disable	1 bit	CRT
This object is only visible when the "Fan level individual objects" parameter is selected. With this object, the fan level 3 is monitored.			

OBJECT	FUNCTION	TYPE	FLAG
Fan Level-4 Feedback	1:Enable / 0:Disable	1 bit	CRT
This object is only visible when the "Fan level individual objects" parameter is selected. With this object, the fan level 4 is monitored.			
Fan Level-5 Feedback	1:Enable / 0:Disable	1 bit	CRT
This object is only visible when the "Fan level individual objects" parameter is selected. With this object, the fan level 5 is monitored.			

4.5 Vane

The following parameters are used for controlling the air vane levels of the air conditioner. When selecting the vane level, refer to the air conditioner's user manual.

Important warning

If scaling is used to change vane values, please consider the following information:

Writing 0% to the "Vane Position" object sets the fan to Auto mode.

Writing 100% to the "Vane Position" object sets the fan to Swing mode.

For this reason, scaling values can be written in the range of 1–99.

We recommend entering the highest value of your selected vane positions as 99%.

Example scenario:

Let's assume the following values:

Vane position 1 limit: 10%

Vane position 2 limit: 50%

Vane position 3 limit: 70%

Vane position 4 limit: 99%

In this case:

If you write 0% to the Vane Position object, the vane will switch to Auto.

If you write 5%, the vane will switch to Vane Position 1.

If you write 70%, the vane will switch to Vane Position 3.

If you write 75%, the vane will switch to Vane Position 4.

If you write 100% to the Vane Position object, the vane will switch to Swing.

As shown in the example, you can switch to any target Vane Position by sending a value between the target level and the level below it.

Important warning

If you are using Scaling for Vane position, the values you enter must not be lower than the previous level.

Correct example:

Vane position 1 limit: 5%
Vane position 2 limit: 30%
Vane position 3 limit: 50%
Vane position 4 limit: 70%
Vane position 5 limit: 100%

Incorrect example:

Vane position 1 limit: 5%
Vane position 2 limit: 30%
Vane position 3 limit: 50%
Vane position 4 limit: 45% // This value should be higher than the Vane position 3 limit
Vane position 5 limit: 100%

In summary: the values must follow this order:

Vane position 1 < Vane position 2 < Vane position 3 < Vane position 4 < Vane position 5

4.5.1 Number of Vane Positions

Number of vane position 4 5

After enabling the vane mode, the number of vane positions in the indoor unit must be defined through the "Number of vane positions" parameter.

4.5.2 Vane Auto Position

Vane auto position Disable Enable

The "Vane Auto Position" parameter defines whether the auto mode for the vane position is available or not.

4.5.3 Swing Mode

Swing mode	<input type="radio"/> Disable	<input checked="" type="radio"/> Enable
------------	-------------------------------	---

The "Swing Mode" parameter defines whether the swing mode for the vane position is available or not.

4.5.4 Vane Position Object

Vane position object	<input type="radio"/> Disable	<input checked="" type="radio"/> Enable
Type	<input checked="" type="radio"/> Enumerated	<input type="radio"/> Scaling

The vane position can be defined in various ways. When the "Vane Positions Object" parameter is activated, the active Vane Position Object allows for data entry to define the vane position. To determine the data type, two options in the "Type" parameter can be selected as Enumerated or Scaling.

If the "Enumerated" option is selected, the data for
Vane auto Position should be "0",
Vane Swing should be "1",
Vane Position 1 should be "2",
Vane Position 2 should be "3",
Vane Position 3 should be "4"

in the "Vane Position" object. If there are 4 vane levels in the system,
Vane auto Position should be "0",
Vane Swing should be "1",
Vane Position 1 should be "2",
Vane Position 2 should be "3",
Vane Position 3 should be "4",
Vane Position 3 should be "5"

in the "Vane Position" object.

If the "Scaling" option is selected, a value can be assigned for each fan level.

Vane position object	<input type="radio"/> Disable	<input checked="" type="radio"/> Enable
Type	<input type="radio"/> Enumerated	<input checked="" type="radio"/> Scaling
Vane position 1 limit	<input type="text" value="10"/>	%
Vane position 2 limit	<input type="text" value="30"/>	%
Vane position 3 limit	<input type="text" value="50"/>	%
Vane position 4 limit	<input type="text" value="70"/>	%
Vane position 5 limit	<input type="text" value="90"/>	%

4.5.5 Vane Position +/- Object

Vane position +/- object	<input type="radio"/> Disable	<input checked="" type="radio"/> Enable
--------------------------	-------------------------------	---

If this parameter is enabled, the "Vane Position +/- Set" group object (1: Increase / 0: Decrease) will be available. If the value 1 is written to the "Vane Position +/- Set" object, the vane will switch to the next higher level. If the value 0 is written to the object, the vane will switch to the next lower level.

4.5.6 Vane Position Individual Object

Vane position individual objects	<input type="radio"/> Disable	<input checked="" type="radio"/> Enable
----------------------------------	-------------------------------	---

By activating the "Vane Position Individual Object," a separate object becomes visible for each vane position, allowing individual vane positions to be set separately.

4.5.7 PARAMETER LIST

Parameter	Sub Par. 1	Sub Par. 2	Values	Conditions	Details
Number of vane position			4/5		This parameter is selected as 4 or 5 levels based on the number of vane positions of the air conditioner.
Vane auto Position			Disable/Enable		This parameter determines whether "Vane aut Position" is available or not.
Swing mode			Disable/Enable		This parameter is used to select whether the swing vane option will be enabled or not.
Vane Position 1			Disable/Enable		This parameter determines whether "Vane Position 1" is available or not.
Vane Position 2			Disable/Enable		This parameter determines whether "Vane Position 2" is available or not.
Vane Position 3			Disable/Enable		This parameter determines whether "Vane Position 3" is available or not.
Vane Position 4			Disable/Enable		This parameter determines whether "Vane Position 4" is available or not.
Vane Position 5			Disable/Enable	If "Number of vane position" selected as "5"	This parameter determines whether "Vane Position 5" is available or not.
Vane position object			Disable/Enable		This parameter determines whether the vane position will be selected by entering data.

Parameter	Sub Par. 1	Sub Par. 2	Values	Conditions	Details
	Type		Enumerated Scaling	<p>If the "Vane Position Object" parameter is enabled</p> <p>If the "Type" sub-parameter is set to "Scaling"</p> <p>If the "Type" sub-parameter is set to "Scaling"</p> <p>If the "Type" sub-parameter is set to "Scaling"</p> <p>If the "Type" sub-parameter is set to "Scaling"</p> <p>If the "Type" sub-parameter is set to "Scaling"</p>	<p>This sub-parameter determines the type of value used to set the vane position.</p> <p>This sub-parameter is used to define the assigned value for Vane Position 1.</p> <p>This sub-parameter is used to define the assigned value for Vane Position 2.</p> <p>This sub-parameter is used to define the assigned value for Vane Position 3.</p> <p>This sub-parameter is used to define the assigned value for Vane Position 4.</p> <p>This sub-parameter is used to define the assigned value for Vane Position 5.</p>
Vane position +/- object			Disable/Enable		This parameter allows switching between vane positions in a +/- manner.
Vane position individual objects			Disable/Enable		This parameter creates a group object for each individual vane position and allows them to be used for separate selection.

4.5.8 OBJECT LIST

OBJECT	FUNCTION	TYPE	FLAG
Vane Auto Position Set	1:Enable / 0:Disable	1 bit	CWU
This object is only visible when the "Vane Auto Position" parameter is enabled. With this object, the air conditioner's vane position can be selected automatically or manually.			

OBJECT	FUNCTION	TYPE	FLAG
Vane Auto Position Feedback	1:Enable / 0:Disable	1 bit	CTR
This object is only visible when the "Vane Auto Position" parameter is enabled. With this object, the air conditioner's vane position can be monitored as automatic or manual.			
Swing Mode	1:Enabled / 0: Disabled	1 bit	CWU
This object is only visible when the "Swing Mode" parameter is enabled. It is used to activate the swing motion of the air conditioner's flaps.			
Swing Mode Feedback	1:Enabled / 0: Disabled	1 bit	CTR
This object is only visible when the "Swing Mode" parameter is enabled. With this object, the air conditioner's vanes can be set to oscillate.			
Vane Position	The % value defined in the parameter.	1 byte	CWU
This object is only visible when the "Vane Position Object" parameter is enabled. With this object, the air conditioner's vane position can be selected by entering percentage values. A percentage value must be assigned for each defined vane position parameter.			
Vane Position	0,1,2,3,4,5,6	1 byte	CWU
This object is only visible when the "Vane Position Object" parameter is enabled. With this object, the vane position is determined by entering values for each vane position. "0" should be entered for automatic vane position, "1" for swing mode, "2" should be entered for Vane-1 position, "3" for Vane-2, "4" for Vane-3, "5" for Vane-4, and "6" for Vane-5.			
Vane Position Feedback	Vane Position Number	1 bit	CRT
This object is visible when the "Vane Position" or "Vane Position +/-" parameter is enabled. With this object, the current air vane position of the air conditioner can be monitored.			
Vane Position +/-	1:Increase/0:Decrease	1 bit	CWU
This object is only visible when the "Vane Position +/- Object" parameter is enabled. With this object, the air vane positions can be adjusted with +/- transitions.			
Vane Position 1 Set	1:Set Position 1 / 0: NA	1 bit	CWU
This object is visible only when the "Vane Position Individual Object" parameter is enabled. With this object, Vane Position 1 can be selected.			
Vane Position 2 Set	1:Set Position 2 / 0: NA	1 bit	CWU
This object is visible only when the "Vane Position Individual Object" parameter is enabled. With this object, Vane Position 2 can be selected.			
Vane Position 3 Set	1:Set Position 3 / 0: NA	1 bit	CWU
This object is visible only when the "Vane Position Individual Object" parameter is enabled. With this object, Vane Position 3 can be selected.			
Vane Position 4 Set	1:Set Position 4 / 0: NA	1 bit	CWU
This object is visible only when the "Vane Position Individual Object" parameter is enabled. With this object, Vane Position 4 can be selected.			

OBJECT	FUNCTION	TYPE	FLAG
Vane Position 5 Set	1:Set Position 5 / 0: NA	1 bit	CWU
This object is visible only when the "Vane Position Individual Object" parameter is enabled. With this object, Vane Position 5 can be selected.			
Vane Position 1 Feedback	1:Enabled / 0: Disabled	1 bit	CRT
This object is visible only when the "Vane Position Individual Object" parameter is enabled. With this object, Vane Position 1 can be monitored.			
Vane Position 2 Feedback	1:Enabled / 0: Disabled	1 bit	CRT
This object is visible only when the "Vane Position Individual Object" parameter is enabled. With this object, Vane Position 2 can be monitored.			
Vane Position 3 Feedback	1:Enabled / 0: Disabled	1 bit	CRT
This object is visible only when the "Vane Position Individual Object" parameter is enabled. With this object, Vane Position 3 can be monitored.			
Vane Position 4 Feedback	1:Enabled / 0: Disabled	1 bit	CRT
This object is visible only when the "Vane Position Individual Object" parameter is enabled. With this object, Vane Position 4 can be monitored.			
Vane Position 5 Feedback	1:Enabled / 0: Disabled	1 bit	CRT
This object is visible only when the "Vane Position Individual Object" parameter is enabled. With this object, Vane Position 5 can be monitored.			

4.6 Wide Vane

Please refer to the "Vane" section, as the settings and functions here are identical to those of the vane.

4.7 AC Temperature

The air conditioner set temperature and ambient temperature are adjusted using the following parameters.

Setpoint temperature feedback	On change or on request
Setpoint temperature +/- object	<input type="radio"/> Disable <input checked="" type="radio"/> Enable
Type	<input checked="" type="radio"/> 1:Increase / 0:Decrease <input type="radio"/> 0:Up / 1:Down
Setpoint temperature limiting	<input checked="" type="radio"/> Disable <input type="radio"/> Enable
Setpoint step	<input checked="" type="radio"/> 1.0 <input type="radio"/> 0.5
Ambient temperature	From bus
Ambient temperature feedback	On change or on request
Selection of thermistor	<input checked="" type="radio"/> Disable <input type="radio"/> Enable

4.7.1 Setpoint Temperature Feedback

The set temperature information can be monitored by activating the "**Setpoint Temperature Feedback**" parameter. This parameter can be activated in three ways:

Setpoint temperature feedback	On request
-------------------------------	------------

The "Setpoint Temperature Feedback" parameter is activated with "On Request" mode, allowing the set temperature to be monitored when requested.

Setpoint temperature feedback	On change or on request
-------------------------------	-------------------------

The "Setpoint Temperature Feedback" parameter is activated with "On Change or On Request" mode, allowing the set temperature to be monitored either when it changes or upon request.

Setpoint temperature feedback	Cyclical or on request
Period	30 Seconds

The "Setpoint Temperature Feedback" parameter is activated with the "Cyclical or On Request" option, allowing the set temperature to be monitored either at a specified interval or upon request. The monitoring interval can be adjusted using the "Period" sub-parameter.

4.7.2 Setpoint Temperature +/- Object

Setpoint temperature +/- object	<input type="radio"/> Disable <input checked="" type="radio"/> Enable
---------------------------------	---

If this parameter is enabled, the "Setpoint Temperature +/-" group object (1: Increase / 0: Decrease) will be available.

If the value "1" is written to the related group address, the set temperature will increase by "+1".
 If the value "0" is written to the related group address, the set temperature will decrease by "-1".

4.7.3 Setpoint Temperature Limiting

Setpoint temperature limiting	<input type="radio"/> Disable <input checked="" type="radio"/> Enable
<div style="border: 1px solid #ccc; padding: 5px; background-color: #e6f2ff;"> <p>i Please check setpoint maximum and minimum limits values according to AC model in technical document !</p> </div>	
Cool mode maximum	30
Cool mode minimum	19
Heat mode maximum	28
Heat mode minimum	17

This parameter allows setting the highest and lowest set temperatures for "**Cool Mode**" and "**Heat Mode**."

Important This field must be configured according to the range specified in the "PARAMETER LIST" table. If a value outside the specified range is entered, the Optimus MitsubishiAC Gateway will stop operating.

4.7.4 Ambient Temperature

Important warning

Optimus MitsubishiAC Gateway accepts a minimum of 8 °C and a maximum of 39 °C for Ambient Temperature. If these limits are exceeded, the closest value within the allowed range will be used.

Ambient temperature	From bus ▼
---------------------	------------

The ambient temperature can be obtained in four different ways and used in air conditioner communication. These are:

- From Bus
- From AC
- From RC

From Bus

If the ambient temperature data is to be sent to the indoor unit via a KNX thermostat, the "Ambient Temperature" parameter should be set to "From Bus".

From AC

If no thermostat or sensor data is to be used and the return air temperature from the air conditioner is preferred, the "Ambient Temperature" parameter should be set to "From AC".

From RC

If the Optimus MitsubishiAC Gateway will operate in parallel with a connected wired remote controller and the ambient temperature from this controller is to be used, the "Ambient Temperature" parameter should be set to "From RC".

4.7.5 Ambient Temperature Feedback

The ambient temperature information can be monitored by activating the "**Ambient Temperature Feedback**" parameter. This parameter can be activated in three different ways:

Ambient temperature feedback	On request ▼
------------------------------	--------------

The "Ambient Temperature Feedback" parameter can be activated with the "on request" option, allowing the ambient temperature to be monitored whenever requested.

Ambient temperature feedback	On change or on request ▼
------------------------------	---------------------------

"on change or on request" – The ambient temperature monitoring is activated when there is a change in the environment temperature or upon request.

Ambient temperature feedback	Cyclical or on request ▼
Period	20 ▲▼ Seconds

"cyclical or on request" – It is activated to monitor either at a specific period or upon request. The desired interval for monitoring the ambient temperature is set in the "Period" sub-parameter.

4.7.6 Virtual Setpoint Calculation

On some Mitsubishi Electric air conditioners that use the CN105 port, it is not possible to transmit the ambient temperature.

If such a unit is being used, the "Virtual Setpoint Calculation" feature can be enabled to maintain comfort temperature operation of the air conditioner.

Enabling Virtual Setpoint Calculation

To enable the Virtual Setpoint Calculation feature:

Ambient temperature	From bus ▼
---------------------	------------

The "Ambient Temperature" parameter must be set to "From Bus",

Selection of thermistor	<input type="radio"/> Disable <input checked="" type="radio"/> Enable
Type	Only AC suction air thermistor ▼

Then, after enabling "Selection of Thermistor", the "Type" parameter should be set to "Only AC suction air thermistor".

How does Virtual Setpoint Calculation work?

When enabled, this feature allows the device to take into account:

The ambient temperature measured by a KNX sensor (KNX Ambient Temperature)

The desired room temperature set by the user (KNX Setpoint Temperature)

The return air temperature reported by the indoor AC unit (AC Suction Air Temperature)

The final setpoint temperature sent to the air conditioner is calculated using the following formula:

$$\text{Adjusted Setpoint} = \text{AC Suction Air Temperature} - (\text{KNX Ambient Temperature} - \text{KNX Setpoint Temperature})$$

Example:

- User's desired temperature (KNX Setpoint): 19°C
- Temperature measured by KNX sensor (KNX Ambient Temp): 21°C
- AC Suction Air Temperature reported by AC unit (AC Return Temp): 24°C

$$24^{\circ}\text{C} - (21^{\circ}\text{C} - 19^{\circ}\text{C}) = 22^{\circ}\text{C}$$

In this example, 22°C will be sent to the AC unit as the effective setpoint.

This calculation ensures that the air conditioner compensates for the temperature difference between what the KNX sensor measures and what the AC unit perceives, always moving the system in the right direction (cooling or heating) to reach the user's desired comfort level.

4.7.7 PARAMETER LIST

Parameter	Sub Par. 1	Sub Par. 2	Values	Conditions	Details
Setpoint temperature feedback	Period		Disable On request On change or on request Cyclical or on request	if selected "Setpoint temperature feedback" parameter as "Cyclical or on request"	This parameter is selected to monitor the air conditioner's "set temperature."not. This sub-parameter adjusts the time period for monitoring the set temperature.
Setpoint temperature +/- Object			Disable/Enable		This parameter allows to change the set temperature step by step.
Setpoint Temperature Limiting	Cool Mode Maximum		19...30		This parameter sets the set temperature limits. This sub-parameter determines the maximum "set temperature" value in cooling mode.
	Cool Mode Minimum		19...30		This sub-parameter sets the minimum set temperature value in cooling mode.

Parameter	Sub Par. 1	Sub Par. 2	Values	Conditions	Details
	Heat Mode Maximum		17...28	If "Setpoint temperature Limiting" parameter is enabled.	This sub-parameter determines the maximum set temperature value in heating mode.
	Heat Mode Minimum		17...28		This sub-parameter sets the minimum set temperature value in heating mode.
Ambient temperature			From bus From AC From RC		This parameter is used to define the source of the Ambient Temperature. One of the following options can be selected: "From Bus", "From AC", or "From RC"
Ambient temperature feedback			Disable On request On change or on request Cyclical or on request	If "Ambient temperature feedback" parameter is set to "Cyclical or onrequest"	This parameter is selected to monitor the ambient temperature.
	Period		5...65535 seconds		This sub-parameter sets the monitoring period for the ambient temperature.

Parameter	Sub Par. 1	Sub Par. 2	Values	Conditions	Details
Selection of thermistor			Disable/Enable		By enabling this parameter, the thermistor source can be selected. When this parameter is enabled, the thermistor source can be selected. If it is not enabled, the thermostat data received by the Kbox will be used as the ambient temperature.
	Type		Only AC suction air thermistor Only RC thermistor	If "Selection of thermistor" parameter enabled.	The correct thermistor must be selected to ensure the desired comfort configuration.

4.7.8 OBJECT LIST

OBJECT	FUNCTION	TYPE	FLAG
Set Point Temperature	Temperature (Celcius)	2 Bytes	CWU
This object is always active. The desired "set temperature" value can be controlled via the linked group address.			
Set Point Temperature Feedback	Temperature (Celcius)	2 Bytes	CTR
This object is always active. The "set temperature" value is monitored via the linked group address.			
Set Point Temperature +/-	1:Increase / 0:Decrease	1 Bit	CWU
This object only appears when the "Setpoint temperature +/- object" parameter is enabled. This object adjusts the AC's "set temperature" in +/- increments.			
Set Point Temperature +/-	0:Up / 1:Down	1 Bit	CWU
This object is only visible when the "Setpoint temperature +/- object" parameter is activated. This object modifies the AC's "set temperature" in -/+ increments.			
Ambient Temperature	Temperature (Celcius) Min:8 Celcius, Max:39 Celsius	2 Bytes	CWU
This object is only visible when the "Ambient temperature" parameter is set to "from bus". This object transmits ambient temperature data to the indoor unit.			
Ambient Temperature Feedback	Temperature (Celcius)	2 Bytes	CRT
This object is always active. Ambient temperature data is monitored through this object.			

4.8 Energy Saving function

Energy-saving functions are configured through the following parameters.

Window contact	Binary input
Binary input no	1
Binary input type	<input checked="" type="radio"/> Normally open <input type="radio"/> Normally closed
Binary input debounce time	50 <input type="text"/> Milliseconds
Input active	No change
Input passive	No change
Occupancy contact	Disable
Sleep contact	Disable

Optimus MitsubishiAC Gateway supports three digital inputs for energy protection functions. These three digital inputs can come from an external source, such as a magnetic contact, or from the KNX bus. The three parameters used for energy protection can have different names but serve the same functions. In summary, the same scenarios can be applied using "Window Contact," "Occupancy Contact," and "Sleep Contact." This section will explain the "Window Contact" parameter, while "Occupancy Contact" and "Sleep Contact" will not be detailed since they have the same functions.

4.8.1 Window Contact

Window contact	Binary input
Binary input no	1
Binary input type	<input checked="" type="radio"/> Normally open <input type="radio"/> Normally closed
Binary input debounce time	10 <input type="text"/> Milliseconds
Input active	No change
Input passive	No change
Occupancy contact	Disable
Sleep contact	Disable

"Window Contact" can be activated by selecting either "Binary input" or "Bus input." If an input will not be received from the KNX bus, "Binary input" should be selected.

Binary Input

Binary input no	1
-----------------	---

The specific input on Optimus MitsubishiAC Gateway for the "Binary input" can be selected using the "Binary input no" option. Any of the three available inputs on the device can be chosen from this menu.

Binary input type	<input checked="" type="radio"/> Normally open <input type="radio"/> Normally closed
-------------------	--

The contact type to be received, whether normally open or normally closed, is determined by the options in the "Binary input type" parameter. Select "Normally open" for a normally open contact and "Normally closed" for a normally closed contact.

Binary input debounce time	<input type="text" value="10"/>	↑ ↓	Milliseconds
----------------------------	---------------------------------	--------	--------------

The time required for the contact to become active again is set using the "Binary input debounce time" option.

Input active	<input type="text" value="AC on"/>		
Delay	<input type="text" value="5"/>	↑ ↓	Seconds

The scenario to be applied when the contact becomes active is selected using the "Input active" parameter. The available options are "No change", "AC on", "AC off" or "Scene". If the air conditioner should turn on after the contact becomes active, the "AC on" option should be selected. The time delay before the air conditioner turns on can be set using the "Delay" option.

Input active	<input type="text" value="AC off"/>		
Delay	<input type="text" value="5"/>	↑ ↓	Seconds

If the air conditioner should turn off after the contact becomes active, the "AC off" option should be selected. The time delay before the air conditioner turns off can be set using the "Delay" option.

Input active	<input type="text" value="Scene"/>		
Scene	<input type="text" value="1"/>	↑ ↓	

If a predefined scenario should be applied after the contact becomes active, the "Scene" option should be selected. As explained in detail in the "Scene Functions" section, Optimus MitsubishiAC Gateway offers 7 scenario options. The desired scenario number should be selected from the "Scene" option, and the delay before the scenario is applied after the contact becomes active should be set using the "Delay" option.

Input passive	AC on
Delay	5 Seconds

When the contact becomes passive, the scenario to be applied can be selected using the "Input passive" parameter. The available options are "No change", "AC on", "AC off", or "Scene". If the air conditioner should turn on after the contact becomes passive, the "AC on" option should be selected. The time delay before the air conditioner turns on can be set using the "Delay" option.

Input passive	AC off
Delay	5 Seconds

If the air conditioner should turn off after the contact becomes passive, the "AC off" option should be selected. The time delay before the air conditioner turns off can be set using the "Delay" option.

Input passive	Scene
Scene	2
Delay	5 Seconds

If a predefined scenario should be applied after the contact becomes passive, the "Scene" option should be selected. As explained in detail in the "Scene Functions" section, Optimus MitsubishiAC Gateway offers 7 scenario options. The desired scenario number should be selected from the "Scene" option, and the delay before the scenario is applied after the contact becomes passive should be set using the "Delay" option.

Bus Input

Optimus MitsubishiAC Gateway also allows scenario creation using inputs received from the KNX bus.

Window contact	Bus input
Input active	No change
Input passive	No change

If an input will be received from the KNX bus, the "Window Contact" parameter should be set to "Bus input."

Input active	AC on
Delay	5 Seconds

To make the air conditioner operate when the input received via the bus becomes active, the "Input active" parameter should be set to "AC on." The time delay before the air conditioner turns on can be set using the "Delay" option.

Input active	AC off
Delay	5 Seconds

To turn off the air conditioner when the input received via the bus becomes active, the "Input active" parameter should be set to "AC off." The time delay before the air conditioner turns off can be set using the "Delay" option.

Input active	Scene
Scene	1
Delay	5 Seconds

To activate a predefined scenario when the input received via the bus becomes active, the "Input active" parameter should be set to "Scene." The desired scenario number should be selected from

Input passive	AC off
Delay	5 Seconds

the "Scene" parameter, and the delay before the scenario is applied after the input becomes active should be set using the "Delay" option.

Input passive	AC on
Delay	5 Seconds

When the input becomes passive, the scenario to be applied can be selected using the "Input passive" parameter. The available options are "No change," "AC on," "AC off," or "Scene." If the air conditioner should turn on after the input becomes passive, the "AC on" option should be selected. The time delay before the air conditioner turns on can be set using the "Delay" option.

If the air conditioner should turn off after the input becomes passive, the "AC off" option should be selected. The time delay before the air conditioner turns off can be set using the "Delay" option.

Input passive	Scene
Scene	2
Delay	5 Seconds

To run a preset scenario when the input from the bus is inactive:

- Set the "Input active" parameter to "Scene".
- Select the desired scenario number from the "Scene" parameter.
- Adjust the "Delay" option to set how long the system should wait before applying the scenario after the input becomes inactive.

4.8.2 PARAMETER LIST

Parameter	Sub Par. 1	Sub Par. 2	Values	Conditions	Details
Window Contact			Disable Binary input Bus input	If "Energy Saving Functions" parameter is set to "Enable"	Determines whether the parameter This parameter configures how a scenario will be applied using the digital input.
	Binary input no		1 2 3	If "Window Contact" parameter is set to "Binary input"	This sub-parameter defines which contact input of the device will be assigned to the Window Contact parameter.
	Binary input type		Normally open Normally Close	If "Window Contact" parameter is set to "Binary input"	This sub-parameter determines whether the external contact will be normally open or normally closed.
	Binary input debounce time		10...255ms	If "Window Contact" parameter is set to "Binary input"	This sub-parameter sets the time for the contact to return to its normal state.
	Input active		No change AC on AC off Scene	If "Window Contact" parameter is set to "Binary input"	This sub-parameter defines which action will be applied when the contact becomes active.
		Scene	1..10	If "Input active" sub parameter is set to "Scene"	This sub-parameter selects which scenario will be applied when the contact becomes active.

Parameter	Sub Par. 1	Sub Par. 2	Values	Conditions	Details
	Input pas- sive	Delay	5...65535 sec- onds	If "Input active" sub parameter not set to "no change"	This sub-parameter determines the delay before transitioning to the selected state after the contact becomes active.
		Scene	1..10	If "Window Con- tact" parameter is set to "Binary input"	This sub-parameter determines which state will be applied when the contact becomes passive.
		Delay	5...65535 sec- onds	If "Input passive" sub-parameter not set to "no change"	This sub-parameter determines the delay before transitioning to the selected state after the contact becomes passive.
Occupancy Contact			Disable Binary input Bus input	If "Energy Saving Funtions" is set to "Enable"	This parameter con- figures how a sce- nario will be applied using the digital input.
	Binary input no		1 2 3	If "Occupancy Contact" param- eter is set to "Binary input"	This sub-parameter defines which contact input of the device will be assigned to the Occupancy Contact parameter.

Parameter	Sub Par. 1	Sub Par. 2	Values	Conditions	Details
	Binary input type		Normally open Normally Close	If "Occupancy Contact" parameter is set to "Binary input"	This parameter determines whether the external contact will be normally open or normally closed.
	Binary input debounce time		10...255 ms	If "Occupancy Contact" parameter is set to "Binary input"	This sub-parameter sets the time for the contact to return to its normal state.
	Input active		No change AC on AC off Scene	If "Occupancy Contact" parameter is set to "Binary input"	This sub-parameter determines which state will be applied when the contact becomes active.
		Scene	1..10	If "Input active" parameter is set to "Scene"	This sub-parameter selects which scenario will be applied when the contact becomes active.
		Delay	5...65535 seconds	If "Input active" sub-parameter is not set to "no change"	This sub-parameter determines the delay before transitioning to the selected state after the contact becomes active.
	Input Passive		No change AC on AC off Scene	If "Occupancy Contact" parameter is set to "Binary input"	This sub-parameter determines which state will be applied when the contact becomes passive.
		Scene	1...10	If "Input passive" sub-parameter is set to "Scene"	This sub-parameter selects which scenario will be applied when the contact becomes passive.

Parameter	Sub Par. 1	Sub Par. 2	Values	Conditions	Details
		Delay	5...65535 seconds	If "Input passive" sub-parameter is not set to "no change"	This sub-parameter determines the delay before transitioning to the selected state after the contact becomes passive.
Sleep Contact			Disable Binary input Bus input	If "Energy Saving Functions" parameter is set to "Enable"	This parameter configures how a scenario will be applied using the digital input.
	Binary input no		1 2 3	If "Sleep Contact" parameter is set to "Binary input"	This sub-parameter defines which contact input of the device will be assigned to the Sleep Contact parameter.
	Binary input type		Normally open Normally Close	If "Sleep Contact" parameter is set to "Binary input"	This parameter determines whether the external contact will be normally open or normally closed.
	Binary input debounce time		10...255 ms	If "Sleep Contact" parameter is set to "Binary input"	This sub-parameter sets the time for the contact to return to its normal state.
	Input active		No change AC on AC off Scene	If "Sleep Contact" parameter is set to "Binary input"	This sub-parameter determines which state will be applied when the contact becomes active.
		Scene	1...10	If "Input active" sub-parameter is set to "Scene"	This sub-parameter selects which scenario will be applied when the contact becomes active.

Parameter	Sub Par. 1	Sub Par. 2	Values	Conditions	Details
	Input pas- sive	Delay	5...65535 sec- onds	If "Input active" altparameter is not set to "no change"	This sub-parameter determines the delay before transitioning to the selected state after the contact becomes active.
			No change AC on AC off Scene	If "Sleep Con- tact" parameter is set to "Binary input"	This sub-parameter determines which state will be applied when the contact becomes passive.
		Scene	1...10	If "Input passive" sub-parameter is set to "Scene"	This sub-parameter selects which sce- nario will be applied when the contact becomes passive.
		Delay	5...65535 sec- onds	If "Input passive" sub-parameter is not set to "no change"	This sub-parameter determines how long after the contact becomes passive the selected state will be applied.

4.8.3 OBJECT LIST

OBJECT	FUNCTION	TYPE	FLAG
Window Contact	1:Enable / 0:Disable	1 bit	CWU
This object is only active when the "Window Contact" parameter is set to "Bus input." It is used for data input via KNX.			
Window Contact Feedback	1:Enable / 0:Disable	1 bit	CTR
This object is only active when the "Window Contact" parameter is set to either "Bus input" or "Binary input." It is used to monitor the "Window Contact" status.			
Occupancy Contact	1:Enable / 0:Disable	1 bit	CWU
This object is only active when the "Occupancy Contact" parameter is set to "Bus input." It is used for data input via KNX.			
Occupancy Contact Feedback	1:Enable / 0:Disable	1 bit	CTR
This object is only active when the "Occupancy Contact" parameter is set to either "Bus input" or "Binary input." It is used to monitor the "Occupancy Contact" status.			

OBJECT	FUNCTION	TYPE	FLAG
Sleep Contact	1:Enable / 0:Disable	1 bit	CWU
This object is only activated when the "Sleep Contact" parameter is set to "Bus input." It is used for data input via KNX.			
Sleep Contact Feedback	1:Enable / 0:Disable	1 bit	CTR
This object is only activated when the "Sleep Contact" parameter is set to "Bus input" or "Binary input." It is used to monitor the "Window Contact" status.			

4.9 Scene function

The "Scene Function" parameter can be enabled by selecting it from the General/Settings section, allowing scenario parameters to be activated.

Startup delay Seconds

Alive notification Disable Enable

Period Seconds

Remote control lock Disable Enable

Object control lock Disable Enable

Energy saving function

Scene function

Additional function

Optimus MitsubishiAC Gateway supports 7 scenario options. Since all 7 scenarios have the same functions, only the Scene 1 parameter will be explained in detail in this section.

4.9.1 Scene 1

Scene 1	<input type="radio"/> Disable <input checked="" type="radio"/> Enable
Number	1
Overwrite on download	<input type="radio"/> Disable <input checked="" type="radio"/> Enable
Delay	5 Seconds
1-bit executer object	<input checked="" type="radio"/> Disable <input type="radio"/> Enable
Save function	<input checked="" type="radio"/> Disable <input type="radio"/> Enable
AC On/Off	No change
AC Mode	No change
AC Setpoint	<input checked="" type="radio"/> No change <input type="radio"/> Value
AC Fan	No change
AC Vane	No change

The "Scene 1...7" parameter can be activated by selecting the "Enable" option.

Number	64
--------	----

Each of the 7 supported scenarios can be assigned a number between 1 and 64 using the Number parameter. It is recommended to assign a unique number to each scenario. However, if the same number is assigned to multiple scenarios, they will be activated simultaneously. In this case, the priority order will be as follows:

Scene 1 > Scene 2 > Scene 3 > Scene 7

For example, if the Number parameter is set to 64 for both Scene 1 and Scene 2, Scene 1 will take priority.

Overwrite on download

Disable Enable

When the Overwrite on download parameter is enabled, a new scenario can be created over the saved scenario. If overwriting the saved scenario is to be prevented, the Overwrite on download parameter should be set to Disable.

Delay

5



Seconds

The Delay parameter allows defining a delay time for the scenario.

1-bit executer object

Disable Enable

To run the scenario with a 1-bit object, the 1-bit executer object parameter must be activated by selecting "Enable."

Save function

Disable Enable

By activating the Save function parameter, the created scenario can be saved.

AC On/Off	On
Delay	0 Seconds
AC Mode	Heat
Delay	0 Seconds
AC Setpoint	<input checked="" type="radio"/> No change <input type="radio"/> Value
AC Fan	Auto
Delay	0 Seconds
AC Vane	Position 1
Delay	0 Seconds

For the selected scenario, the air conditioner's on/off status, mode, set temperature, fan level, and vane position can be defined. Separate delays for each status can be set using the Delay parameter. If the current operating conditions of the air conditioner are to be saved as a scenario, a separate delay time for the scenario cannot be defined; instead, the delays selected for each air conditioner status will be recorded.

4.10 Save/Exec Function

The device provides a single Save/Exec group object based on DPT 18.001 (Scene Control). This object supports both executing a stored scene and saving the current operating state as a scene. All scenes use the same communication object and are controlled by sending a command value together with a scene number.

1. Executing a Scene

To run a previously saved scene, send the value Activate along with the desired scene number. When a scene is executed, the device applies all parameters that were stored for that scene. This ensures that the air conditioner returns to the exact saved operating state.

2. Saving a Scene

If the Save Function is enabled for the selected scene in the parameters, the current air-conditioner state can be stored as a scene. To save a scene, send the value Learn together with the target scene number. The device then records the current operating state under that scene number. The stored scene can later be recalled using the Activate command.

Notes

Saving is only possible when the Save Function for the selected scene is enabled.

Executing a scene always applies the full saved state.

4.10.1 PARAMETER LIST

Parameter	Sub Par. 1	Sub Par. 2	Values	Conditions	Details
Scene 1...7	Number		1...64	If the Scene Function is selected from the General/Settings section. If "Scene 1...7" parameter is set to "Enable"	This parameter defines the relevant scenario variables. This sub-parameter defines the numerical value assigned to the "Scene 1...7" parameter.
	Overwrite on download		Disable/Enable	If "Scene 1...7" parameter is set to "Enable"	This sub-parameter determines whether a new scenario can be overwritten on the saved scenario.
	Delay		0...65535 seconds	If "Scene 1...7" parameter is set to "Enable"	This sub-parameter determines the delay time before the scenario starts.
	1-bit executor object		Disable/Enable	If "Scene 1...7" parameter is set to "Enable"	This sub-parameter determines whether the scenario can be activated using a 1-bit object.
	Save function		Disable/Enable	If "Scene 1...7" parameter is set to "Enable"	This sub-parameter allows the scenario to be saved.

Parameter	Sub Par. 1	Sub Par. 2	Values	Conditions	Details
	AC on/off	Delay	No change On Off	If "Scene 1...7" parameter is set to "Enable"	This sub-parameter allows selecting the air conditioner's on/off state when the scenario conditions are met.
			0...65535 seconds	If "Ac on/off" parameter is not set to "No change"	This sub-parameter allows selecting the delay time for executing the air conditioner's on or off command.
	AC Mode	Delay	No change Cool Heat Dry(Dehumifcation) Fan (Fan Only) Auto	If "Scene 1...7" parameter is set to "Enable"	This parameter allows selecting the air conditioner's mode when the scenario conditions are met.
			0...65535 seconds	If "Ac Mode" parameter is not set to "No change"	This parameter determines the delay time for the air conditioner's mode change.
	AC Set-point	Value	No change Value	If "Scene 1...7" parameter is set to "Enable"	This parameter selects the set temperature state of the air conditioner when the scenario conditions are met.
			17...28 C	If "Ac Setpoint" parameter is not set to "No change"	This parameter sets the value of the set temperature.
	AC Set-point	Delay	0...65535 seconds	If "Ac Setpoint" parameter is not set to "No change"	This parameter sets the delay time for the set temperature.

Parameter	Sub Par. 1	Sub Par. 2	Values	Conditions	Details
	AC Fan		No change Auto Level 1 Level 2 Level 3 Level 4	If "Scene 1...7" parameter is set to "Enable"	This parameter determines the fan speed level of the air conditioner when the scenario conditions are met.
		Delay	0...65535 seconds	If "Ac Fan" parameter is not set to "No change"	This parameter defines the delay time for changing the fan speed level.
	AC Vane		No change Auto Swing Position 1 Position 2 Position 3 Position 4 Position 5	If "Scene 1...7" parameter is set to "Enable"	This sub-parameter defines the louver position when the scenario conditions are met.
		Delay	0...65535 seconds	If "Ac Vane" parameter is not set to "No change"	This sub-parameter sets the delay time for the louver position change.

4.10.2 OBJECT LIST

OBJECT	FUNCTION	TYPE	FLAG
Scene Exec / Save	Value or "Learn"	1 byte	CWU
This object is only activated when the "Scene Function" is selected from the "General/Settings" section. It is used to input values for the scenario or to record a scenario using the "learn" option.			
Scene 1 Exec	1:trigger / 0:trigger	1 bit	CWU
This object is only activated when the "1-bit executer object" parameter is set to "Enable" in the Scene-1 parameter. It allows Scene-1 to operate with a 1-bit object.			
Scene 2 Exec	1:trigger / 0:trigger	1 bit	CWU
This object is only activated when the "1-bit executer object" parameter is set to "Enable" in the Scene-2 parameter. It allows Scene-1 to operate with a 1-bit object.			
Scene 3 Exec	1:trigger / 0:trigger	1 bit	CWU
This object is only activated when the "1-bit executer object" parameter is set to "Enable" in the Scene-3 parameter. It allows Scene-1 to operate with a 1-bit object.			

OBJECT	FUNCTION	TYPE	FLAG
Scene 4 Exec	1:trigger / 0:trigger	1 bit	CWU
This object is only activated when the "1-bit executer object" parameter is set to "Enable" in the Scene-4 parameter. It allows Scene-1 to operate with a 1-bit object.			
Scene 6 Exec	1:trigger / 0:trigger	1 bit	CWU
This object is only activated when the "1-bit executer object" parameter is set to "Enable" in the Scene-6 parameter. It allows Scene-1 to operate with a 1-bit object.			
Scene 7 Exec	1:trigger / 0:trigger	1 bit	CWU
This object is only activated when the "1-bit executer object" parameter is set to "Enable" in the Scene-7 parameter. It allows Scene-1 to operate with a 1-bit object.			

4.11 Additional Function

The "Additional Function" parameter can be selected from the General/Settings section to activate the scenario parameters.

Startup delay Seconds

Alive notification Disable Enable

 Period Seconds

Remote control lock Disable Enable

Object control lock Disable Enable

Energy saving function

Scene function

Additional function

Optimus MitsubishiAC Gateway supports 10 functions defined as "Additional Function." Each function includes 7 customizable logic functions, 4 arithmetic operations, 6 different comparison operations, and 3 different data type conversion features. Since all 10 functions share the same characteristics, only the "Function 1" parameter will be explained in detail in this section.

4.11.1 Function 1

Function 1	<input type="radio"/> Disable <input checked="" type="radio"/> Enable
Type	Logic ▼
Operation	NOT ▼
Input 1 type	<input checked="" type="radio"/> Constant value <input type="radio"/> Object
Value	<input checked="" type="radio"/> False <input type="radio"/> True
Output size	1-Bit ▼
Output delay	5 <input type="text"/> Seconds
Output sending	Disable ▼

Logic

The "Type" parameter includes four different variables: "Logic" for logic functions,

- "Arithmetic" for arithmetic operations,
- "Comparison" for comparison operations,
- "Conversion" for data type conversion.

Type	Logic ▼
Operation	NOT ▼

With the "Logic" option, seven different logic operations can be performed. The desired logic operation can be selected from the "Operation" parameter.

Operation NOT

For the logical NOT operation, the "Operation" parameter should be set to "NOT". When the "NOT" operation is selected, only a single input option will be available.

Input 1 type Constant value Object
Value False True

The "Input 1 type" parameter can be assigned as either a constant value or an object. To assign an object, the "Input 1 type" parameter must be set to "Object." If a constant value is to be assigned, "Constant value" should be selected. When "Constant value" is selected, the "Value" parameter becomes active, allowing the selection of "False" or "True" as the assigned constant value.

Operation AND

For the logical AND operation, the "Operation" parameter must be set to "AND." When the "AND" operation is selected, two input options become active.

Input 1 type Constant value Object
Value False True
Input 2 type Constant value Object

The "Input 1 type" and "Input 2 type" parameters allow selecting either an object or a constant value for the logical AND operation.

Operation OR

Input 1 type	<input checked="" type="radio"/> Constant value	<input type="radio"/> Object
Value	<input checked="" type="radio"/> False	<input type="radio"/> True
Input 2 type	<input type="radio"/> Constant value	<input checked="" type="radio"/> Object

Operation	XOR
-----------	-----

For the logical OR operation, the "Operation" parameter should be set to "OR." When "OR" is selected, two input options become active.

The "Input 1 type" and "Input 2 type" parameters allow selecting either an object or a constant value for the logical OR operation.

For the logical EXCLUSIVE OR operation, the "Operation" parameter must be set to "XOR." When "XOR" is selected, two input options become active.

Input 1 type	<input checked="" type="radio"/> Constant value	<input type="radio"/> Object
Value	<input checked="" type="radio"/> False	<input type="radio"/> True
Input 2 type	<input type="radio"/> Constant value	<input checked="" type="radio"/> Object

The "Input 1 type" and "Input 2 type" parameters allow selecting between an object and a constant value for the EXCLUSIVE OR (XOR) logical operation.

Operation	NAND
-----------	------

For the logical NAND operation, the "Operation" parameter should be set to "NAND." When "NAND" is selected, two input options become active.

Input 1 type	<input checked="" type="radio"/> Constant value	<input type="radio"/> Object
Value	<input checked="" type="radio"/> False	<input type="radio"/> True
Input 2 type	<input type="radio"/> Constant value	<input checked="" type="radio"/> Object

Input 1 type	<input checked="" type="radio"/> Constant value	<input type="radio"/> Object
Value	<input checked="" type="radio"/> False	<input type="radio"/> True
Input 2 type	<input type="radio"/> Constant value	<input checked="" type="radio"/> Object

The "Input 1 type" and "Input 2 type" parameters allow the selection of either an object or a constant value for the NAND logical operation.

Operation	NOR
-----------	-----

The "Operation" parameter should be set to "NOR" for the logical NOR operation. When "NOR" is selected, two input options become active.

The "Input 1 type" and "Input 2 type" parameters allow the selection of either an object or a constant value for the logical NOR operation.

Operation	NXOR
-----------	------

The "Operation" parameter should be set to "NXOR" for the logical Exclusive NOR (XNOR) operation. When "NXOR" is selected, two input options become active.

Input 1 type	<input checked="" type="radio"/> Constant value	<input type="radio"/> Object
Value	<input checked="" type="radio"/> False	<input type="radio"/> True
Input 2 type	<input type="radio"/> Constant value	<input checked="" type="radio"/> Object

The "Input 1 type" and "Input 2 type" parameters allow the selection of either an object or a constant value for the Exclusive NOR (XNOR) logical operation.

Type	Arithmetic ▼
Input size	<input checked="" type="radio"/> 1-Byte <input type="radio"/> 2-Byte

Arithmetic When the "Type" parameter is set to "Arithmetic," the "Input size" parameter becomes active, allowing the selection of input size as either "1-Byte" or "2-Byte" for arithmetic operations. With the "Arithmetic" option, four different arithmetic operations can be performed.

Operation	Addition ▼
-----------	------------

For the addition operation, the "Operation" parameter must be set to "Addition."

Operation	Subtraction ▼
-----------	---------------

For the subtraction operation, the "Operation" parameter must be set to "Subtraction."

Operation	Multiplication ▼
-----------	------------------

For the multiplication operation, the "Operation" parameter must be set to "Multiplication."

Type	Comparison
Input size	<input checked="" type="radio"/> 1-Byte <input type="radio"/> 2-Byte
Operation	Equal to

Operation	Division
-----------	----------

For the division operation, the "Operation" parameter must be set to "Division."

When the "Arithmetic" option is selected from the "Type" parameter, two input options become active.

Input 1 type	<input checked="" type="radio"/> Constant value <input type="radio"/> Object
Value	0
Input 2 type	<input type="radio"/> Constant value <input checked="" type="radio"/> Object

The "Input 1 type" and "Input 2 type" parameters can be assigned either as a fixed value or as an Object. To assign an object, the "Object" option should be selected. If a fixed value is to be assigned, the "Constant value" option should be chosen. When "Constant value" is selected, the "Value" parameter becomes active. The assigned value must comply with the selection in the "Input size" parameter:

- If "1-Byte" is selected, a value between 0-255 can be entered.
- If "2-Byte" is selected, a value between 0-65536 can be entered.

All four arithmetic operations can be adjusted according to these value assignments.

Comparison

When the "Comparison" option is selected from the "Type" parameter, the "Input size" parameter becomes active. Here, the size of the inputs for the comparison operation can be set to either "1-Byte" or "2-Byte". With the "Comparison" operation, six different comparisons can be performed:

- Equal
- Not Equal
- Greater Than
- Greater Than or Equal
- Less Than
- Less Than or Equal

Operation	Equal to
-----------	----------

For the Equal operation, the "Operation" parameter should be set to "Equal to".

Operation	Not equal to
-----------	--------------

For the Not Equal operation, the "Operation" parameter should be set to "Not equal to".

Operation	Greater than
-----------	--------------

For the Greater than operation, the "Operation" parameter should be set to "Greater than".

Operation	Greater than or equal to
-----------	--------------------------

For the Greater than or equal to operation, the "Operation" parameter should be set to "Greater than or equal to".

Operation	Less than
-----------	-----------

For the Less than operation, the "Operation" parameter should be set to "Less than".

Type	Conversion
Input size	1-Bit
Operation	<input checked="" type="radio"/> 1-Bit to 1-Byte <input type="radio"/> 1-Bit to 2-Byte

Operation	Less than or equal to
-----------	-----------------------

For the Less than or equal to operation, the "Operation" parameter should be set to "Less than or equal to".

When the "Comparison" option is selected from the "Type" parameter, two input options become active.

Input 1 type	<input checked="" type="radio"/> Constant value <input type="radio"/> Object
Value	0
Input 2 type	<input type="radio"/> Constant value <input checked="" type="radio"/> Object

The "Input 1 type" and "Input 2 type" parameters can be assigned either as a fixed value or as an object.

- To assign an object, select the "Object" option.
- To assign a fixed value, select "Constant value".

When "Constant value" is selected, the "Value" parameter becomes active. The assigned value depends on the "Input size" parameter:

- If "1-Byte" is selected, the value can be between 0-255.
- If "2-Byte" is selected, the value can be between 0-65536.

Conversion

When the "Type" parameter is set to "Conversion", the "Input size" parameter becomes active. Here, the input size for conversion can be selected as:

- "1-Bit"
- "1-Byte"
- "2-Byte"

The "Operation" parameter determines the target size to which the input will be converted.

Input size	1-Bit
Operation	<input checked="" type="radio"/> 1-Bit to 1-Byte <input type="radio"/> 1-Bit to 2-Byte

For example, if the "Input Size" is set to "1-Bit", the "Operation" parameter can be set to "1-Bit to 1-Byte" to convert a 1-bit input into a 1-byte value.

Input 1 type	<input checked="" type="radio"/> Constant value <input type="radio"/> Object
Value	<input checked="" type="radio"/> False <input type="radio"/> True

If "Input Size" is set to "1-Bit", and the "Input 1 type" parameter is set to "Constant Value", the "Value" parameter allows selecting either "False" or "True" for the 1-bit data.

Input 1 type	<input checked="" type="radio"/> Constant value <input type="radio"/> Object
Value	0

If "Input Size" is set to "1-Byte", and "Input 1 type" is set to "Constant Value", the "Value" parameter allows entering a value between 0-255. If "Input Size" is set to "2-Byte", the "Value" parameter allows entering a value between 0-65536. When the "Type" parameter is set to "Conversion", only one input value can be entered.

Input 1 type	<input type="radio"/> Constant value <input checked="" type="radio"/> Object
--------------	--

In addition to entering a constant value, an object value can also be assigned. In this case, the "Input 1 type" parameter should be set to "Object".

Output size	1-Bit
Output delay	1-Bit ✓
Output sending	1-Byte
	2-Byte

Output delay	5	Seconds
--------------	---	---------

Output

Output size	1-Bit	
Output delay	5	Seconds
Output sending	Disable	

When the "Function 1" parameter is activated with the "enable" option, the following parameters become active as the function's output: "Output size" to determine the output size, "Output delay" to set the output delay time, and "Output sending" to define the output transmission method.

With the "Output size" parameter, the following options can be selected:

- "1-Bit"
- "1-Byte"
- "2-Byte"

These options allow setting the output size to 1 bit, 1 byte, or 2 bytes.

The "Output delay" parameter allows setting the output delay time in seconds.

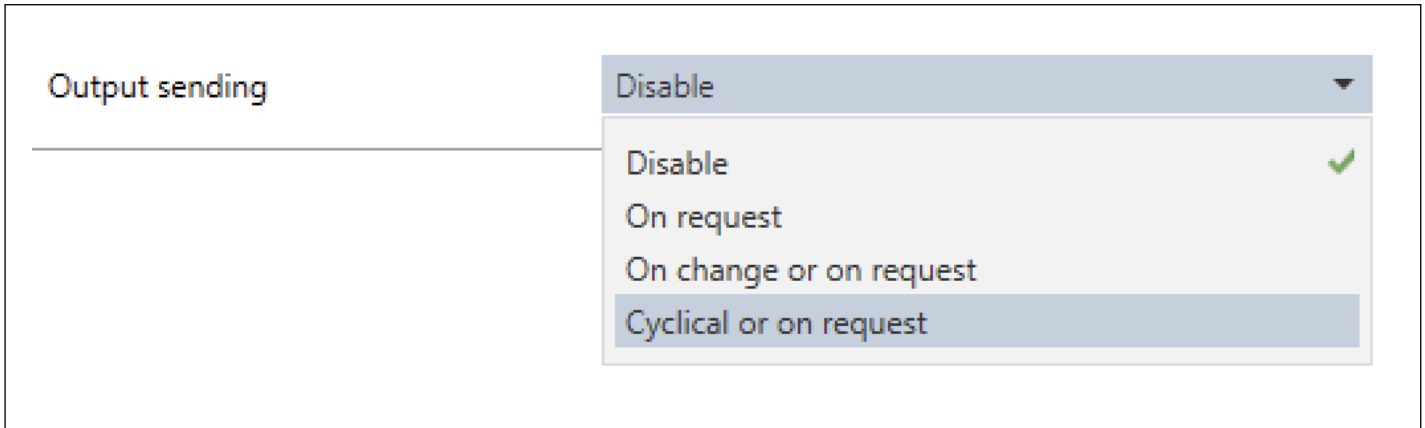

The "Output sending" parameter determines how the output is transmitted.

- "On request": The output is sent only when requested.
- "On change or on request": The output is sent either when it changes or upon request.

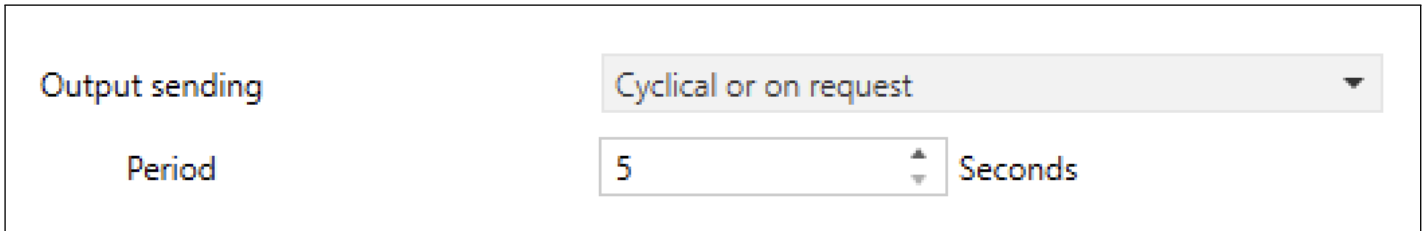

The "Output sending" parameter, when set to "Cyclical or on request", ensures that the output is transmitted either upon request or at regular intervals. The transmission frequency is defined in seconds using the "Period" parameter.

4.11.2 PARAMETER LIST

Parameter	Sub Par. 1	Sub Par. 2	Values	Conditions	Details
Function 1...10	Type		Disable/Enable Logic Arithmetic Comparison Conversion	If "Additional Function" is selected from the "General/Settings" section. If Function 1...10 "Enable" is selected.	With this parameter, Logic, Arithmetic, Comparison, and Conversion functions are used.. This parameter allows the selection of Logic, Arithmetic, Comparison, and Conversion functions.

Parameter	Sub Par. 1	Sub Par. 2	Values	Conditions	Details
	Input size		1-Byte 2-Byte	If the "Type" parameter is set to "Arithmetic" or "Comparison"	This parameter determines the size of the input value.
	Input size		1-Bit 1-Byte 2-Byte	If the "Type" parameter is set to "Conversion"	This parameter determines the size of the input value.
	Operation		Addition Subtraction Multiplication Division	If the "Type" parameter is set to "Arithmetic"	With this parameter, arithmetic operations are selected.
	Operation		Equal to Not equal to Greater than Greater than or equal to Less than Less than or equal to	If the "Type" parameter is set to "Comparison"	With this parameter, comparison operations are selected.
	Operation		1-Bit to 1-Byte 1-Bit to 2-Byte	If the "Type" parameter is set to "Conversion" and the "Input size" parameter is set to "1-Bit".	This parameter is used to select conversion operations.
	Operation		1-Byte to 1-Bit 1-Byte to 2-Byte	This parameter is used to select conversion operations, and if the "Input size" parameter is set to "1-Byte"	This parameter is used to select conversion operations.
	Operation		2-Byte to 1-Bit 2-Byte to 1-Byte	This parameter is used to select conversion operations, and if the "Input size" parameter is set to "2-Byte"	This parameter is used to select conversion operations.

Parameter	Sub Par. 1	Sub Par. 2	Values	Conditions	Details
	Input type 1	Value	Constant Value Object False True	<p>If Function 1...10 is set to "Enable", the function will be activated.</p> <p>If the "Input 1 type" parameter is set to "Constant value" and the "Input size" parameter is set to "1-Bit," the "Value" parameter becomes active, allowing the selection of either "False" or "True."</p>	<p>This parameter is used to determine the input type.</p> <p>This parameter is used to define the input values.</p>
		Value	0...255	<p>If the "Input 1 type" parameter is set to "Constant value" and the "Input size" parameter is set to "1-Byte"</p>	<p>This parameter is used to define the input values.</p>
		Value	0-65535	<p>If 'Input 1 type' is set to 'Constant value' and the 'Input size' parameter is set to '2-Byte'</p>	<p>This parameter is used to define the input values.</p>
	Input type 2	Value	Constant Value Object False True	<p>If 'Function 1...10' is set to 'Enable' and the 'Type' parameter is not set to 'Conversion'</p> <p>If "Input 1 type" is set to "Constant value" and the "Input size" parameter is set to "1-Byte"</p>	<p>This parameter determines the type of the second input.</p> <p>This parameter defines the second input value.</p>

Parameter	Sub Par. 1	Sub Par. 2	Values	Conditions	Details
		Value	0...255	If "Input 1 type" is set to "Constant value" and the "Input size" parameter is set to "1-Byte"	This parameter defines the second input value.
		Value	0-65535	If "Input 1 type" is set to "Constant value" and the "Input size" parameter is set to "2-Byte"	This parameter defines the second input value.
	Output Size		1-Bit 1-Byte 2-Byte	If "Function 1...10" is set to "Enable"	This parameter defines the output size.
	Output delay		0...65535 seconds	If "Function 1...10" is set to "Enable"	This parameter is used to define the output delay time.
	Output sending		Disable On request On change or on request Cyclical or on request	If "Function 1...10" is set to "Enable"	This parameter defines when and how the output will be sent.
		Period	5...65535 seconds	If "Output sending" is set to "Cyclical or on request"	This parameter defines how often the output will be sent, in seconds.

4.11.3 OBJECT LIST

OBJECT	FUNCTION	TYPE	FLAG
Input 1	1:True / 0: False	1 bit	CWU
This object is only active when "Input 1 type" is set to "Object" and "Input size" is set to "1-Bit". It provides input with a 1-bit object for "Function 1...10"			
Input 2	1:True / 0: False	1 bit	CWU
This object is only activated when "Input 2 type" is set to "Object" and "Input size" is set to 1 bit. It provides input with a 1-bit object for Function 1...10.			

OBJECT	FUNCTION	TYPE	FLAG
Input 1	1:True / 0: False	1 Byte	CWU
This object is only active when "Input 1 type" is set to "Object" and "Input size" is set to "1-Byte". It provides input with a 1-byte object for Function 1...10.			
Input 2	1:True / 0: False	1 Byte	CWU
This object is only active when "Input 2 type" is set to "Object" and "Input size" is set to "1-Byte". It provides input with a 1-byte object for Function 1...10.			
Input 1	1:True / 0: False	2 Byte	CWU
This object is only active when "Input 1 type" is set to "Object" and "Input size" is set to "2-Byte". It provides input with a 2-byte object for Function 1...10.			
Input 2	1:True / 0: False	2 Byte	CWU
This object is only active when "Input 2 type" is set to "Object" and "Input size" is set to "2-Byte". It provides input with a 2-byte object for Function 1...10.			
Output	1:True / 0: False	1 Bit	CR
This object is only active when "Output size" is set to "1-Bit" and the "Output sending" parameter is set to "On request". It provides output with a 1-bit object for Function 1...10.			
Output	1:True / 0: False	1 Byte	CR
This object is only active when "Output size" is set to "1-Bit" and the "Output sending" parameter is set to "On request". It provides output with a 1-bit object for Function 1...10.			
Output	1:True / 0: False	2 Byte	CR
This object is only active when "Output size" is set to "2-Byte" and the "Output sending" parameter is set to "On request". It provides output with a 2-byte object for Function 1...10.			
Output	1:True / 0: False	2 Byte	CR
This object is only active when "Output size" is set to "2-Byte" and the "Output sending" parameter is set to "On request". It provides output with a 2-byte object for Function 1...10.			
Output	1:True / 0: False	1 Bit	CRT
This object is only active when "Output size" is set to "1-Bit" and the "Output sending" parameter is set to either "On change or request" or "Cyclical or on request". It provides output with a 1-bit object for Function 1...10.			
Output	1:True / 0: False	1 Byte	CRT
This object is only active when "Output size" is set to "1-Byte" and the "Output sending" parameter is set to either "On change or request" or "Cyclical or on request". It provides output with a 1-byte object for Function 1...10.			
Output	1:True / 0: False	2 Byte	CRT
This object is only active when "Output size" is set to "2-Byte" and the "Output sending" parameter is set to either "On change or request" or "Cyclical or on request". It provides output with a 2-byte object for Function 1...10.			

5 Main Technical Features

Device	Optimus MitsubishiAC Gateway
Power Supply	EIB Power Supply
Power Consumption	10mA
Inputs	3 dry contact inputs
Button	1 x KNX programming button
LED	1 x KNX programming LED
Operating Mode	S-Mod
Protection Type	IP 20
Temperature	Working (-10°C...70°C) Storing (-25°C...90°C)
Maximum Humidity	<90RH
Flammability	Non-flammable material
Color	Black
Dimensions	44.5x19.8x44.5 mm (WxHxD)
Configuration	With ETS

6 Wiring Diagram

The Optimus MitsubishiAC Gateway is connected to the indoor unit of the air conditioner as shown below.

6.1 CN105 Port

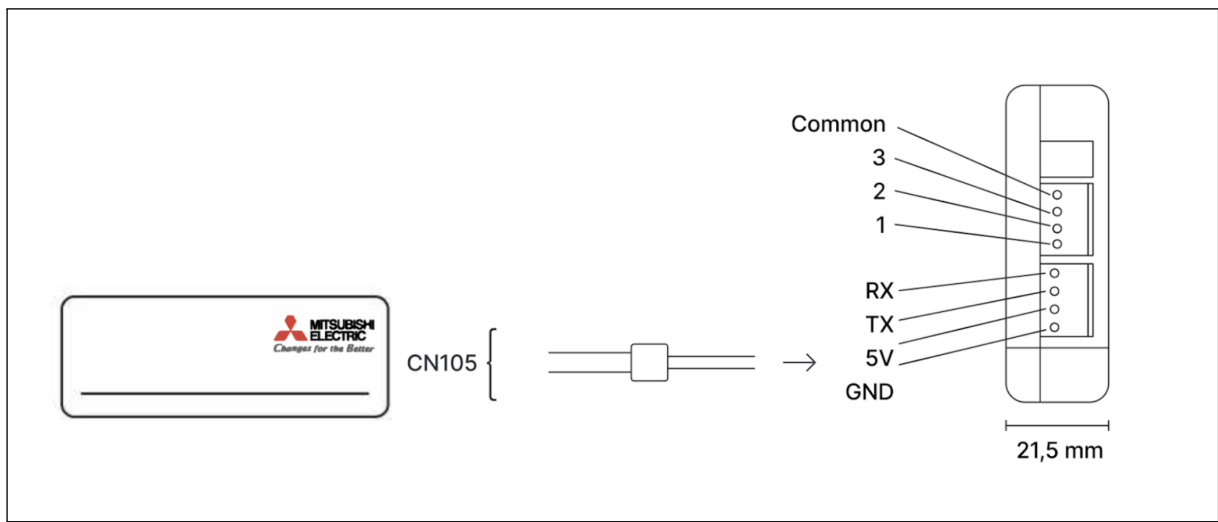

6.2 TB15 Port

